

**ATTENZIONE: Il documento è incompleto. I diagrammi mancanti vanno costruiti dallo studente. Un simbolo ? in una lista indica che può essere vuota**

Program

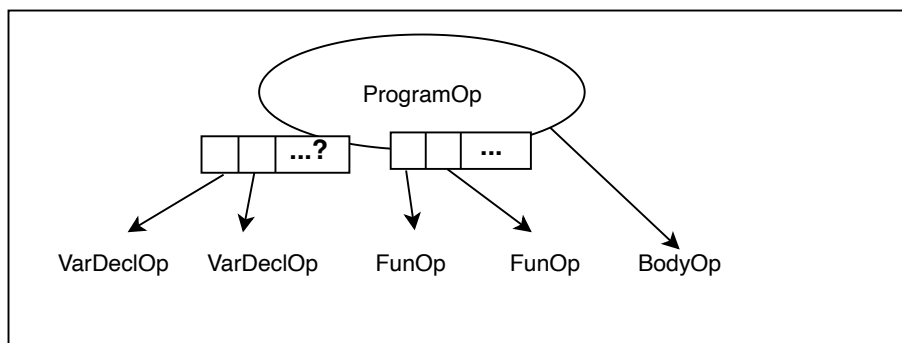

Fun

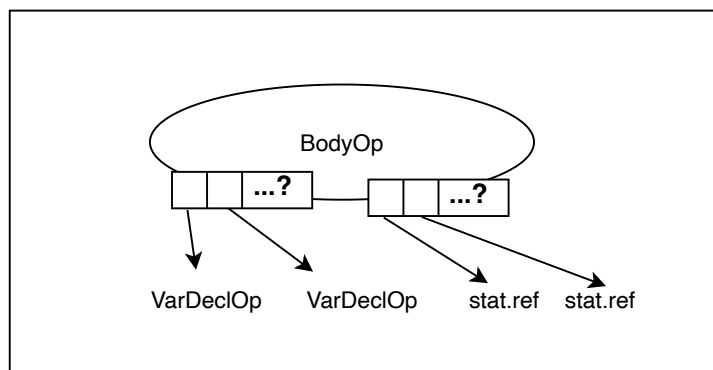
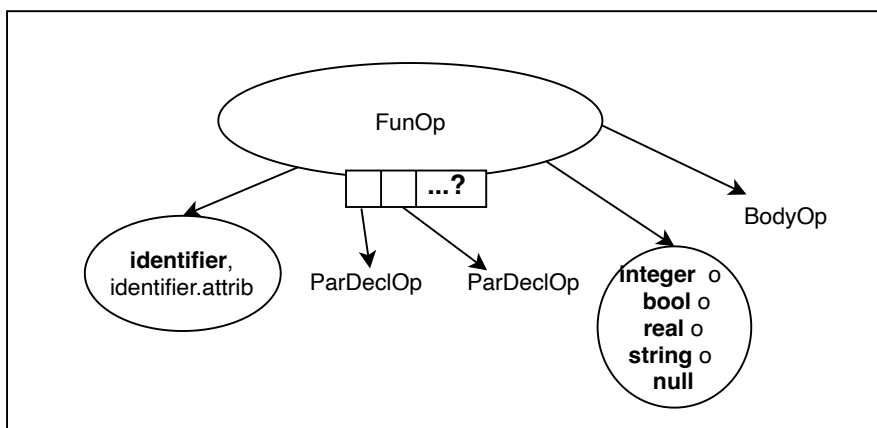

Par\_decl

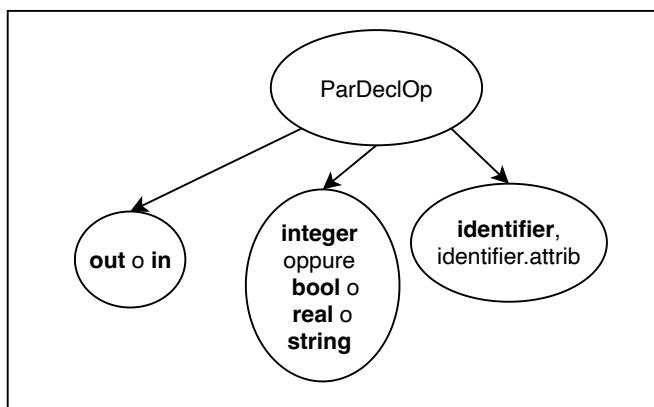

VarDecl

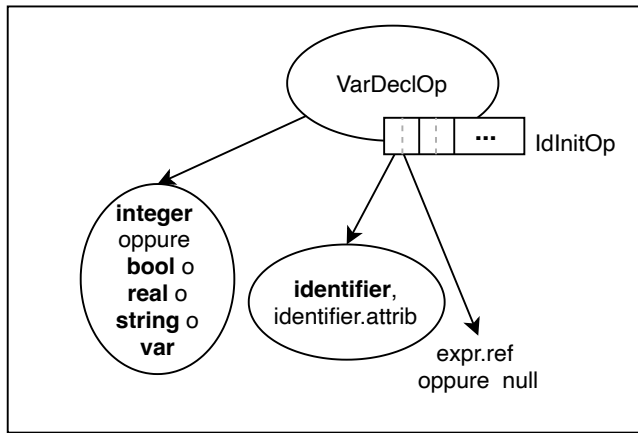

ReadStat

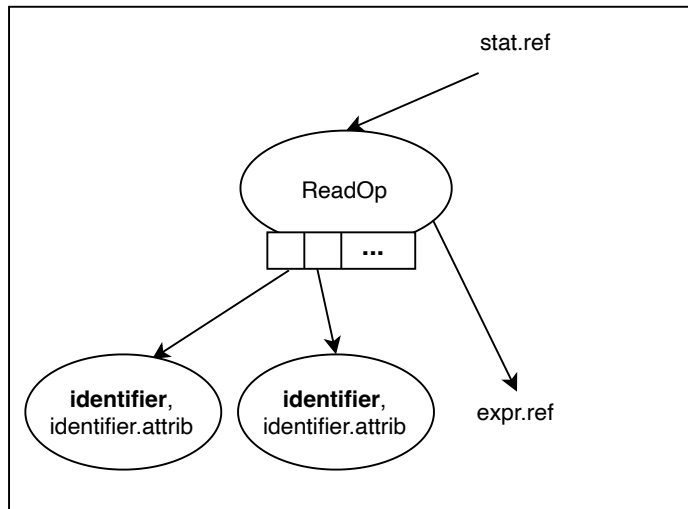

WriteStat

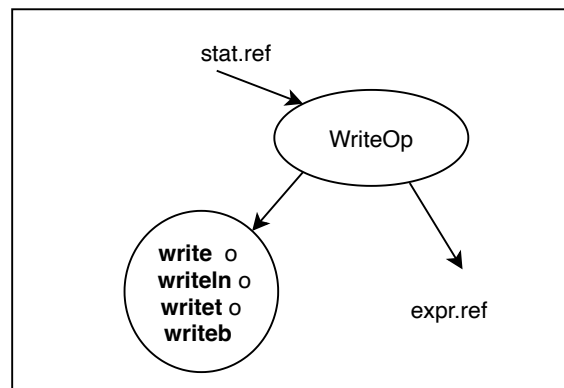

AssignStat

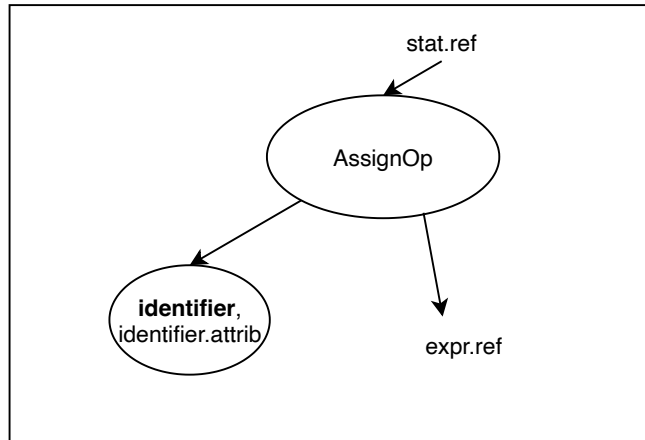

CallFun

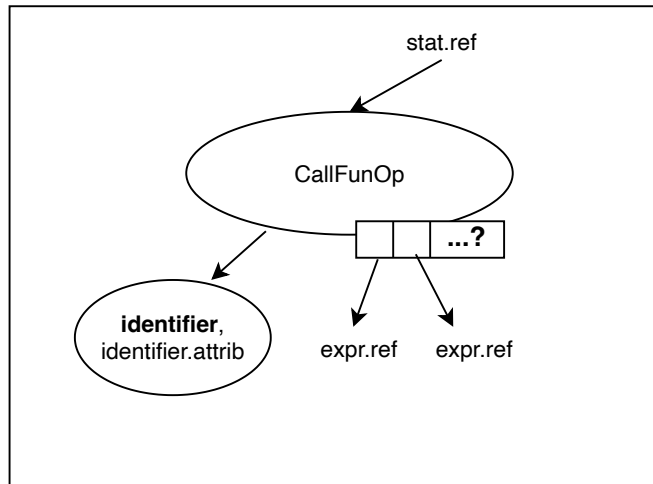

WhileStat

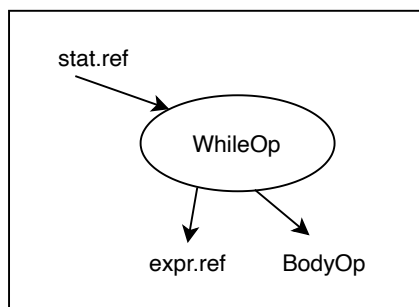

IfStat

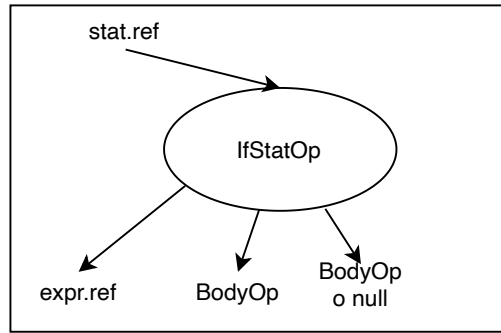

Expr

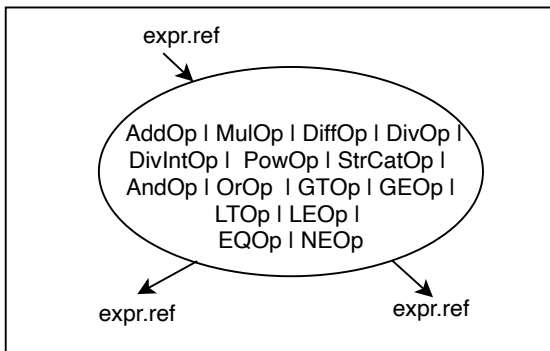

OR

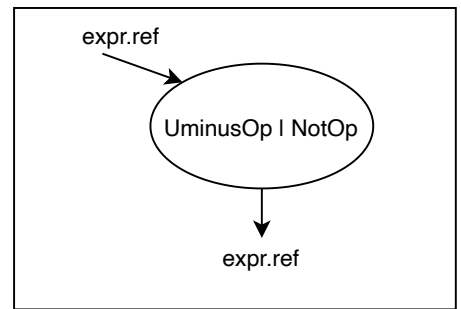

OR

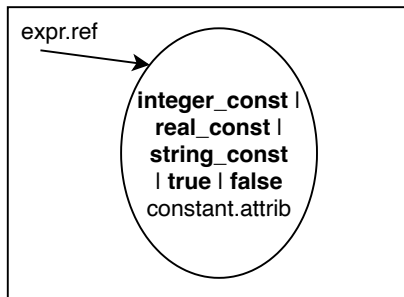

OR

